

MJC
Multiple Joist Connector

The multi joist connector (MJC) allows two I-joists/metal web joists to be fixed together to act as a single unit, transferring the incoming load from the loaded ply to the unloaded ply. The MJC is an improved solution to the traditional filler block detail, which historically has been time consuming to fit and difficult to check if fitted correctly. It's simple and effective design allows one size of product to be used on any joist size – regardless of height or width.



Features

Materials

- Pre-galvanised mild steel

Advantages

- Quick and simple to install
- Safely joins multiple joists together, allowing them to act as a single unit
- Easy to see that MJCs are installed (where as filler blocks are not visible)
- One size product fits all joist height and width combinations

Features

The MJC is an improved solution to the traditional filler block detail, which historically has been time consuming to fit and difficult to check if fitted or if fitted correctly. It's simple and effective design allows one size of product to be used on any joist size – regardless of height or width.

- Quick and simple to install.
- Safely joins multiple joists together, allowing them to act as a single unit.
- Easy to see that MJC's are installed (where as filler blocks are not visible).
- One size product fits all joist height and width combinations.
- Just one nail size required: 3.75 x 30mm square twist.

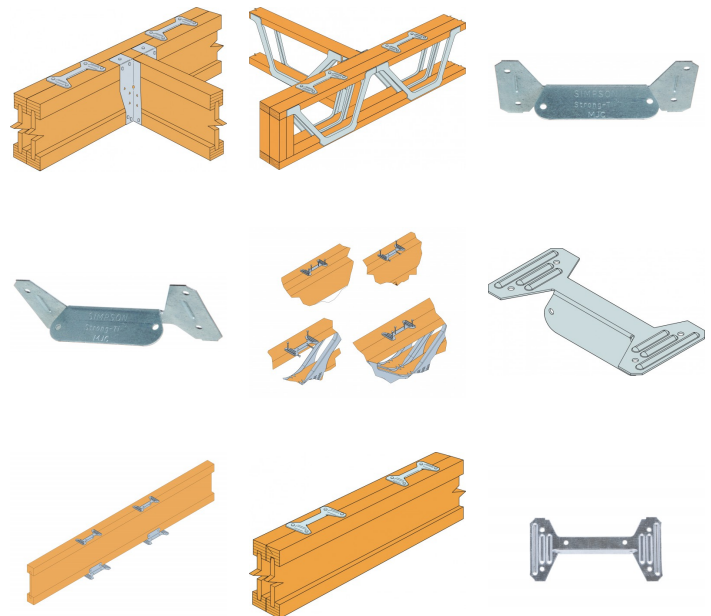

MJC Multiple Joist Connector

Technical Data

MJC Product Dimensions

References	Dimensions [mm]				Header Holes	Joist Holes
	A	B	C	t	Ø4.1	Ø4.1
MJC	133	29	65	1.2	6	2

Product Capacities - Max Incoming Point Load

References	Product Capacities - Max. Incoming Point Load ⁽¹⁾								
	Qty ⁽²⁾	Fasteners per MJC		Characteristic Capacities [kN]			Safe Working Loads [kN]		
		Joist 1	Joist 2	R _{1,k}			R _{1,SWL, Long Term}		
		Qty N3.75x30	Qty N3.75x30	I-Joists		Metal Web	I-Joists		Metal Web
		LVL	Solid Sawn	LVL	Solid Sawn				
MJC (x4)	4	4	4	16.6	15.3	12.6	6.9	6.4	5.3
MJC (x8)	8	4	4	24.9	22.9	18.9	10.3	9.6	7.9

1. Maximum point load that can be applied when connectors are installed either side of the load
2. Number of connectors equally spaced about the incoming load

Product Capacities - Maximum Incoming Regular Load

References	Product Capacities - Max. Incoming Regular Load ⁽³⁾								
	Qty ⁽²⁾	Fasteners per MJC		Characteristic Capacities [kN]			Safe Working Load [kN]		
		Joist 1	Joist 2	R _{1,k}			R _{1,SWL, Long term}		Metal Web
		Qty N3.75x30	Qty N3.75x30	I-Joists		Metal Web	I-Joists		
		LVL	Solid Sawn	LVL	Solid Sawn				
MJC (x2)	2	4	4	8.3	7.6	6.3	3.4	3.2	2.3
MJC (x4)	4	4	4	12.4	11.4	9.4	5.1	4.8	3.5

1. Maximum point load that can be applied when connectors are installed either side of the load
2. Number of connectors equally spaced about the incoming load
3. Maximum load that can be applied at regular intervals along the supporting joist

MJC Multiple Joist Connector

Installation

Installation

- Position the MJC onto the first joist, ensuring that they are centred about the incoming load at 400 c/c (may be adjusted within 10mm each way).
- Secure each MJC with 4 No. 3.75 x 30mm Square Twist Nails, 2 No. fasteners into the joists top face (or for the lower flange MJC, the joists bottom face) and 2 no. fasteners into the joists front face, as shown.
- Position the second joist ensuring ends are flush and joists are parallel. Secure the joist to the MJC using 4no. 3.75 x 30mm Square Twist Nails per MJC into the top (or bottom flange) as shown.

